

FIRST TIME IN INDIA, CHAIN ELECTRIC HOISTS,
PACKED IN UNIQUE, ONE OF A KIND,
DUST & MOISTURE PROOF, PORTABLE BAG.



HOIST PACKED IN CONVENIENT MOULDED CARRYING CASE WITH BUILT IN HANDLE.



DRIVER



SINGLE PHASE, FOR CONVENIENT IN HOUSE USE WITH ITS EASY PORTABILITY.



Manufactured by :
R. N. SURESH TOOLS CORPN.
53, Commercial Chambers,
Masjid Bunder Road, Mumbai - 400 003.
Tel. : +91 22 2643 7697
Telefax : +91 22 2643 7796
rnstools@hotmail.com
www.speedrns.com

SPEED®
SINGLE PHASE/DUAL SPEED

S SERIES



THE NEW
POWER SAVER
HOIST



S Series
CHAIN ELECTRIC HOISTS
Single Phase/Dual Speed

Established : 1964

R. N. SURESH TOOLS CORPN.

Warranty
We provide one year's
Warranty against any
manufacturing defects
Ex. Our works



POWERFUL – LOW ENERGY CONSUMPTION – SAFE

- Single phase , convenient in house use.
- Available voltage 220V - AC (+/-10%), 50 Hz.
- Permanent Magnet Brushless Motor, Ip 54, with F Class Insulation having overheat protection.
- Dual speed, with infinitely variable low speed through adjustable pendant control button.
- Variable frequency control, low starting current, high efficiency, energy saving.
- Protection : (1) Clutch overload device.
(2) Up/ down limit switches.
(3) Emergency Stop button.
- Electrical control, has protection, easy to identify breakdown cause, easy installation and maintenance.
- Provides high reliability and long life.
- Low noise, <75 db.
- Compact design - with a moulded case packing- easy to carry.



PERMANENT MAGNET – BRUSHLESS MOTOR FOR NEW GENERATION HOISTS

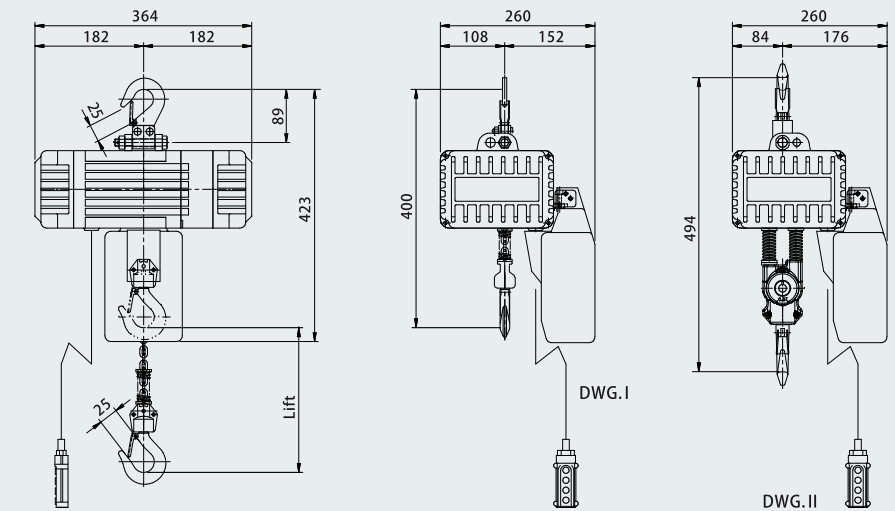

Technical Specifications

Rated Power Source	Single Phase , 220 V - AC (+/- 10%) , 50 Hz.													
Model	DWG.	Rated Load (kg)	Motor Output (W)	Time Rating (min)	Intermittent Duty		Rated Current (A)	Lifting Speed (m/min)	Standard Lift (m)	Push Button Cord (m)	Load Chain Diameter (mm)	No. of falls.	N.W./G.W. (kg)	
					%ED	Max Starting Frequency (times/hr)							3m	6m
SD - 008	I	80	300	15	30	180	6.0(110V) 3.0(220V)	0~4.8/18	3	3	4X12	1	16.5/	17.5/
SD - 012	I	120						0~3.2/12.5					19.5/	20.6
SD - 016	I	160	600	15	30	180	10.0(110V) 5.0(220V)	0~4.8/18	3	3	4X12	1	16.5/	17.5/
SD - 024	I	240						0~3.2/12.5					19.5/	20.6
SD - 032	II	320	600	15	30	180	10.0(110V) 5.0(220V)	0~2.4/9	3	3	4X12	2	19.4/	21.5/
SD - 048	II	480						0~1.6/6.3					22.4/	24.5

※ Packing (L x W x H) : 500 x 390 x 205 (mm) ※ Maximum Push Button Cable Length 20m

Chain Bucket No. Selection Table

Model	Capacity (kg)	No. of falls.	Load Chain (mm)	Lift (mm)																								Bucket No.	Sizes L x W x H (mm)
				3	4	5	6	7	8	9	10	11	12	13	14	15	16	17	18	19	20	21	22	23	24				
SD - 008	80	1	Ø4x12	BD1#				BD2#				BD3#				BD4#				BD1#	90X130X245								
SD - 012	120	1		BD1#				BD2#				BD3#				BD4#				BD2#	120X160X230								
SD - 016	160	1		BD1#				BD2#				BD3#				BD4#				BD3#	130X170X260								
SD - 024	240	1		BD1#				BD2#				BD3#				BD4#				BD4#	130X170X310								
SD - 032	320	2		BD1#	BD2#	BD3#	BD4#	X																					
SD - 048	480	2																											